

# DMK大注射量PET专用注塑机

LARGE SHOT WEIGHT PET PREFORM INJECTION MACHINE



**DEMARK**

# DMK-PET SERIES PROFESSIONAL AND STABLE PREFORM PRODUCTION

## 专业稳定的瓶坯生产

- 1 锁模力小,注射量大,合适各种瓶坯模具的要求。
- 2 液压马达,低速高扭矩,装填原料稳定快速。
- 3 特别为PET原料设计的大直径螺杆和螺杆桶。
- 4 增加了脱模力和行程,改善脱模速度。
- 5 装备了特殊冷却水分配器和空气压缩阀,易于操作。
- 6 最大模具高度可允许各种型号的瓶坯模具。
- 7 模板可根据瓶坯模具来打孔,取消锁模板以固定模具。
- 8 装备槽孔,便于传输瓶坯。

- 1 Small clamping unit with large shot weight, suitable for different PET preform mould requirements.
- 2 Equip with low speed and high torque hydraulic motor which is good for charging material stably and fast.
- 3 Big diameter screw and barrel, special design for PET material.
- 4 Increased ejector force and stroke to improve the ejecting speed.
- 5 Equip with special cooling water distributor and compressed air valve for easy operation.
- 6 Max mould height is big for different type preform mould.
- 7 Platen hole could be drilled specially according to preform mould, cancel clamp plate for fixing mould.
- 8 Equipped with socket for preform conveyor.



DMK170PET

DMK210PET

DMK270PET

DMK320PET

模板尺寸图 Platen Dimensions

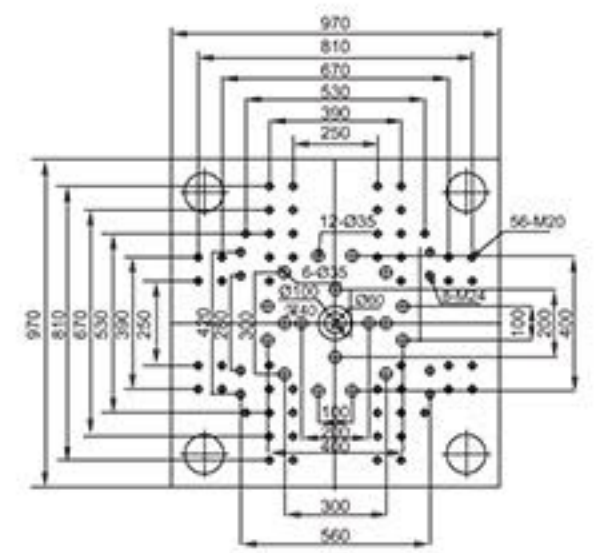
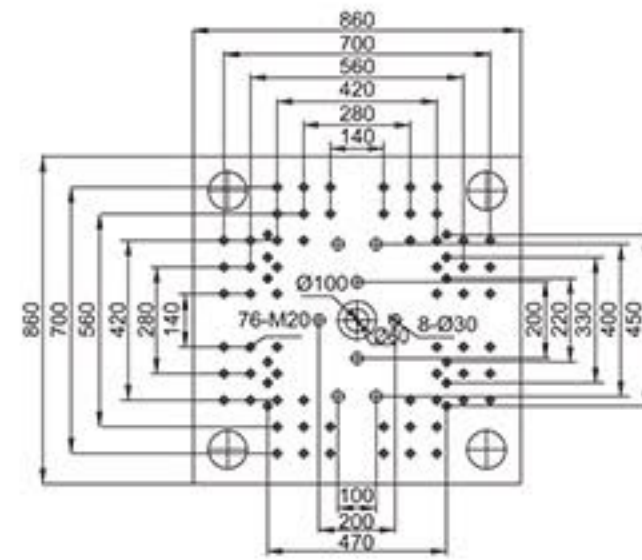
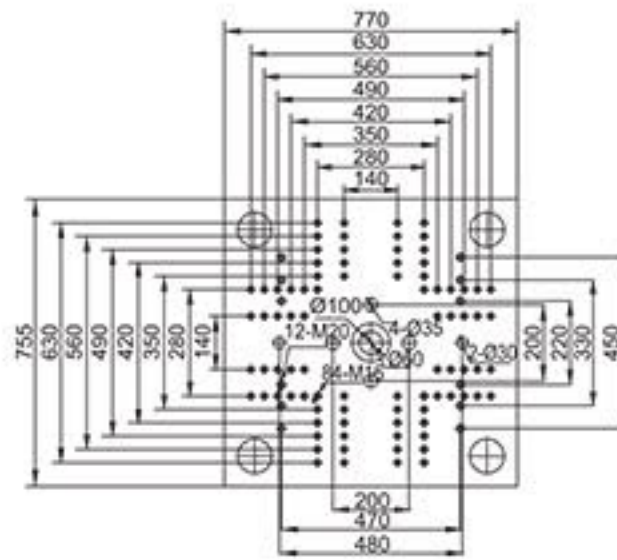
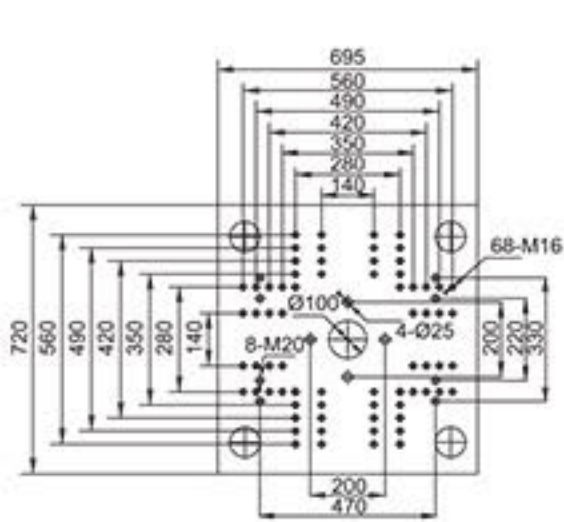

模板侧面尺寸 Mould Space Dimensions

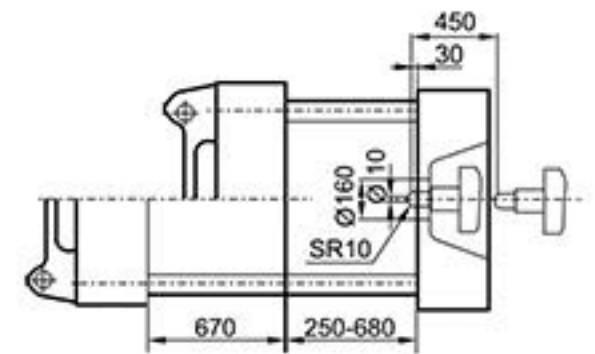
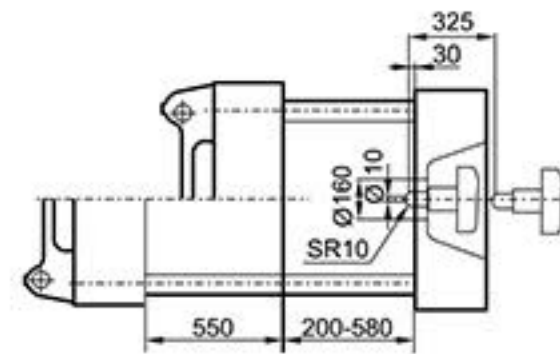
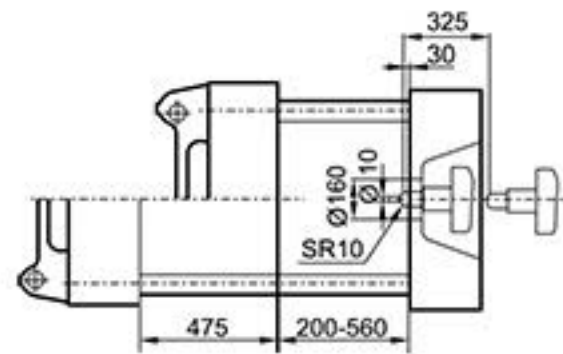
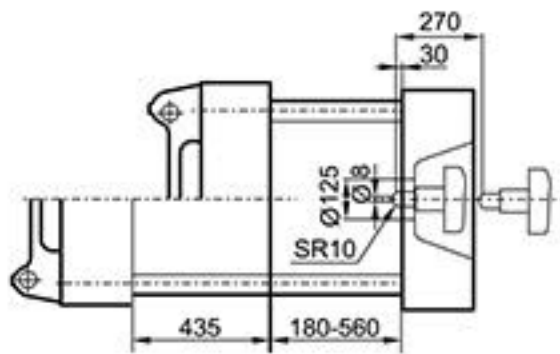

安装图 Floor Flan Layout

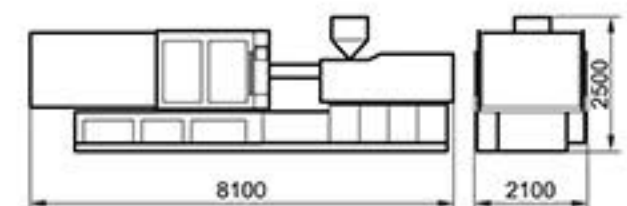
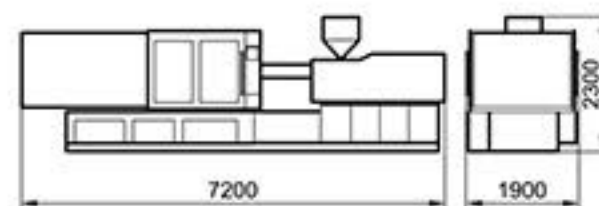
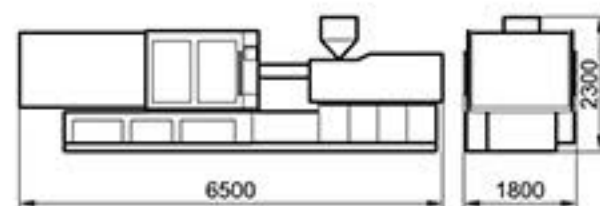
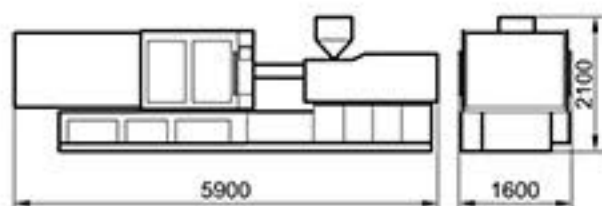

# MAIN TECHNICAL FEATURES

## 主要技术参数

MODEL		UNIT	DMK170PET	DMK210PET	DMK270PET	DMK320PET	
注射装置 Injection Unit	螺杆直径	Screw Diameter	mm	65	70	75	80
	螺杆长径比	Screw L/D Ratio		25	25	25	25
	理论注射容量	Shot Volume	cm <sup>3</sup>	895	1134	1479	1959
	注射重量	Injection Weight	g	961	1224	1597	2115
	注射速率	Injection Rate	g/s	384	465	400	528
	注射压力	Injection Pressure	Mpa	130	130	150	165
	螺杆转速	Screw Speed	rpm	134	126	126	139
锁模装置 Clamping Unit	合模力	Clamping Force	kn	1700	2100	2700	3200
	移动模板行程	Moving Plate Stroke	mm	435	475	550	670
	最大模厚	Max.Mould Height	mm	560	560	580	680
	最小模厚	Min.Mould Height	mm	180	200	200	250
	拉杆间距 (宽×高)	Tie Bars Space(W×H)	mm	470×470	520×520	580×580	660×660
	液压顶出力	Ejector force	kn	70	90	90	150
	液压顶出行程	Ejector Stroke	mm	135	140	150	165
顶出点数	Ejector Number	n	5	7	9	13	
其它 Others	最大油泵压力	Max.Pump Pressure	Mpa	16	16	16	16
	油泵电机功率	Pump Motor Power	kw	30	37	37	45
	加热功率	Heating Power	kw	22.3	22.7	30.7	36.7
	外形尺寸	(L×W×H)Size	M	5.9×1.6×2.0	6.5×1.8×2.3	7.2×1.9×2.3	8.1×2.1×2.5
	机器重量	Machine Weight	T	6.5	7.5	9.5	14

德玛克保留对产品进行修改的权利，规格如有变动，恕不另行通知。

Demark reserve the rights to make any product improvement or specification change without prior notice.